

DOOR LOOP SDM 30

Door loop type SDM 30 - is a wire conduit to protect exposed wires in order not to be damaged.

PROPERTIES

: Door loops are **protective means for guiding wires from the frame to doors with installed electrical devices** such as electric locks.

: **Can be attached to a tapered panel with a width of 25 mm.**

: It needs a **minimum of space**. It is suitable for narrow door spaces due to its small design.

: **Easy to maintain.**



DIMENSIONS



TECHNICAL SPECIFICATIONS

Model:	SDM 30
Connector material:	Embedded box and connector: Iron
Conduit material:	Spring steel
Inner diameter of the conduit:	10,4 mm
Vnější průměr pružiny:	13,8 mm
Outside diameter of the conduit:	250 mm
Total length:	325 mm
Weight:	283 g

STRUCTURE DIAGRAM

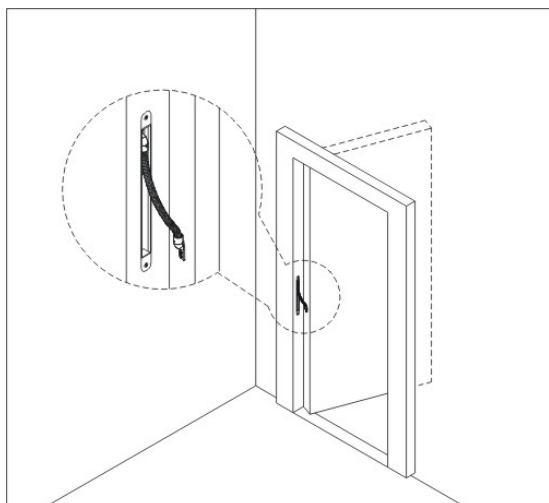

The leader in door opening solution
www.zadlabacipruchoodky.cz
www.acssolution.cz

Updated: 9/2022 | ACS Solution s.r.o. Specifications are subject to change without prior notice. Note: The colors of the images in this brochure may differ from the actual colors.